

nordman®
profile LTD.

NORDMAN TILE SHEETS

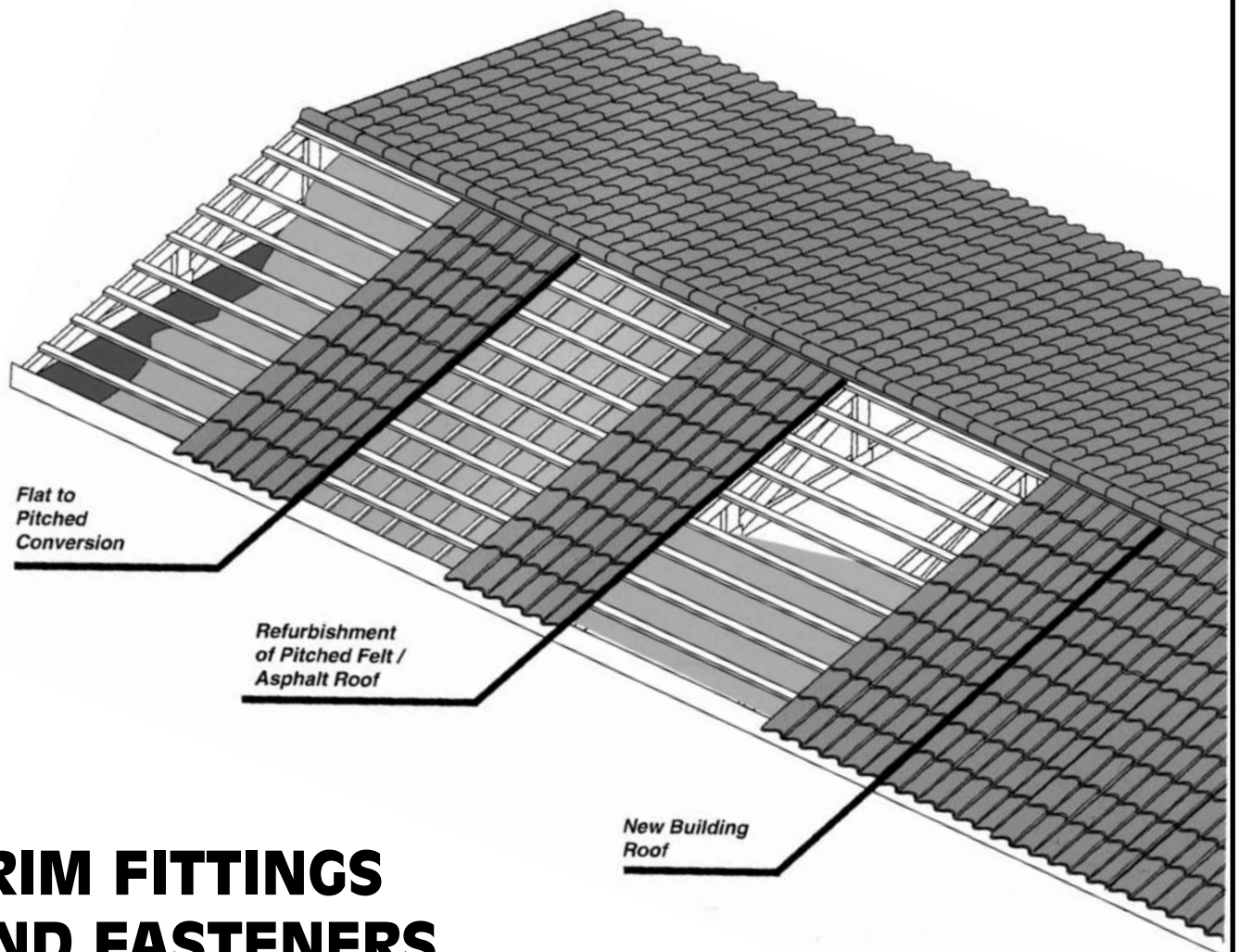

TRIM FITTINGS AND FASTENERS

Fixing Instructions

Head Office and Factory
Kilrush Business Park
Kilrush, Co. Clare
Tel.: 065-9052011/9051553
Fax: 065-9051507

Cavan Office:
Telephone: 043-83126
Fax: 043-83360

Call Save: 1850 211 711
Email: nordman@nordman.ie
<http://www.nordman.ie>

SPECIFICATIONS

Material	Galvanised/Alu-zinc, Coated Steel
Coat	200 microns Plastisol leather grain
Weight	5kg/m ²
Covering Width	1050mm
Standard Colours	Black, Brown, Grey, Clay Red & Olive Green
Sheet Thickness	0.5mm

SHEET LENGTHS MANUFACTURED TO CUSTOMERS REQUIREMENTS:

Sheets can be fabricated to meet specific requirements in lengths up to 8 Meters. However to facilitate site handling and freight costs we recommend a maximum length of 4.685 Meters.

Standard Lengths Covering Area Roof Pitches

mm	tile no.	allowing for side laps (m ²)
485	1	0.5m ²
1185	3	1.24m ²
1885	5	1.98m ²
2235	6	2.35m ²
4335	12	4.55m ²

Standard Side Overlap 4° to vertical

On site Storage
Store on flat surface.
Keep covered and dry.

NOTE: When combining standard length subtract 135mm from each additional sheet to calculate total length e.g. 4335 +2235 =6435

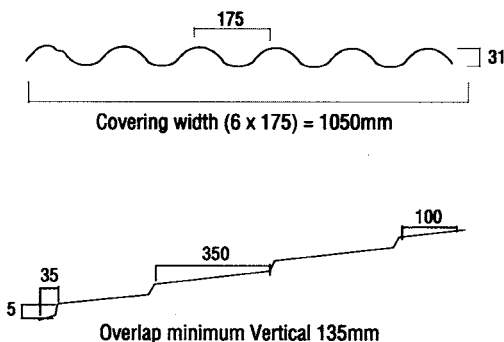

Nordman Profile Limited

Head Office and Factory,
Kilrush Business Park
Kilrush, Co. Clare, Ireland

Tel.: + 353 (0)65 9052011 / 9051553
Fax: + 353 (0)65 9051507



Cavan Office

Phone: 00 353 (0)43 83126
Fax: 00 353 (0)43 83360

Call Save: 1850 211 711
Email: nordman@nordman.ie
<http://www.nordman.ie>

VENTILATION

To eliminate condensation in all roofs, the Building Regulations 1990, Part F2 and BS5250 1989, stipulate the following:

1. *Duo pitched, lean to and mono pitched roofs (insulation at joist level)*–
These require 10,000mm² per meter of ventilation at the eaves plus 5,000mm² per meter at the ridge or high level.
2. *Duo pitched, lean to an mono pitched roofs (insulation at rafter level)*–
These require 25,000mm² per meter of ventilation at the eaves plus 5,000mm² per meter at the ridge or high level.

All ventilation components must be designed to prevent the ingress of rain, snow, birds and large insects. The minimum gap size must not be less than 4mm to avoid excessive airflow resistance.

Minimum requirements for all opening dimensions in mm –

5	=	5,000mm ² per linear meter.
10	=	10,000mm ² per linear meter.
25	=	25,000mm ² per linear meter.
50	=	50mm minimum air path.

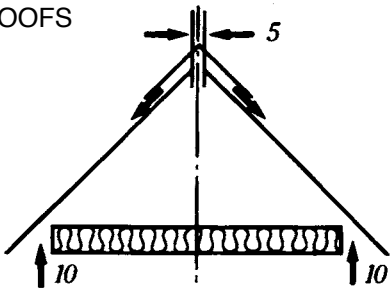
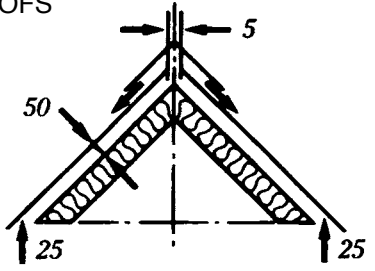
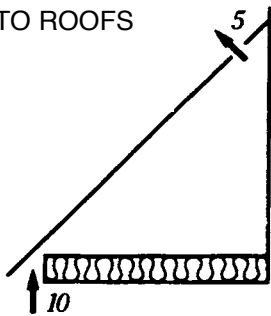
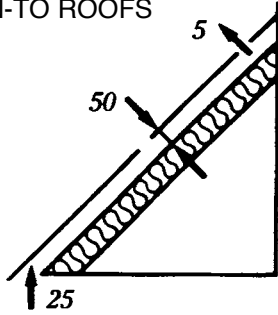
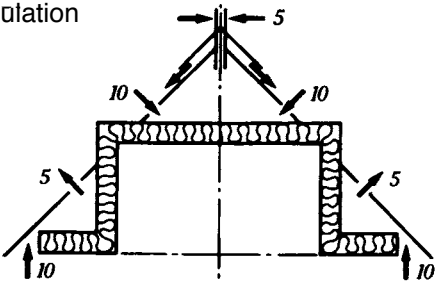
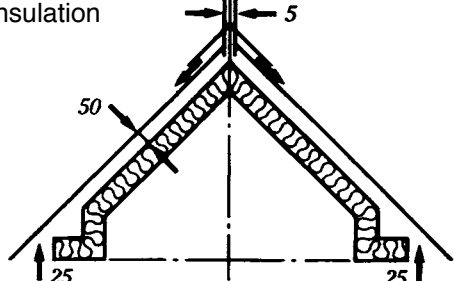
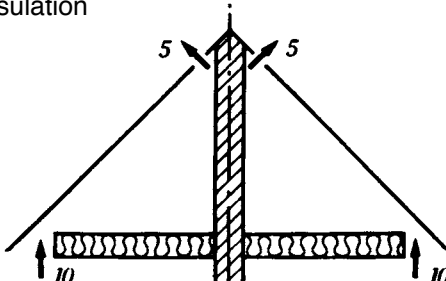
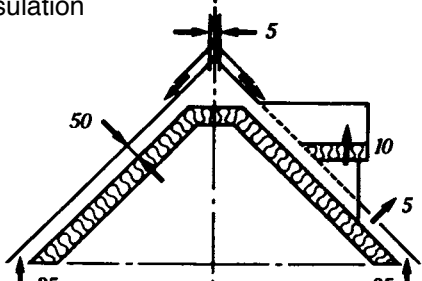

VENTILATION PATHS

<p>DUO-PITCHED ROOFS Ceiling insulation</p> 	<p>DUO-PITCHED ROOFS Rafter insulation</p> 
<p>MONO OR LEAN-TO ROOFS Ceiling insulation</p> 	<p>MONO OR LEAN-TO ROOFS Rafter insulation</p> 
<p>ATTIC/LOFT OR CHALET TYPE ROOFS Rafter insulation</p> 	<p>ATTIC/LOFT OR CHALET TYPE ROOFS Rafter insulation</p> 
<p>BACK-TO-BACK DUO ROOFS Ceiling insulation</p> 	<p>PITCHED ROOF DORMERS Rafter insulation</p> 

STATUTORY OBLIGATIONS

The roof structure should comply to all Building Regulations

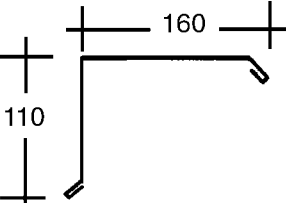
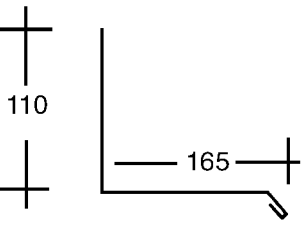
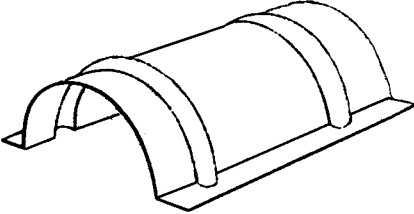
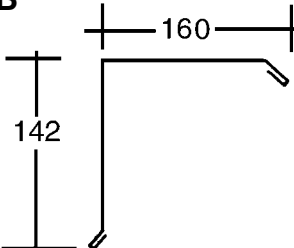
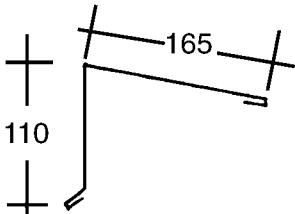
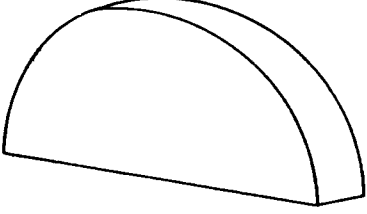
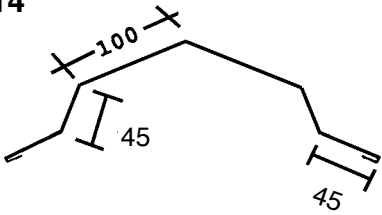
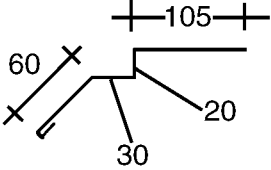
ROOFING ACCESSORIES

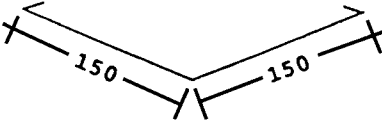
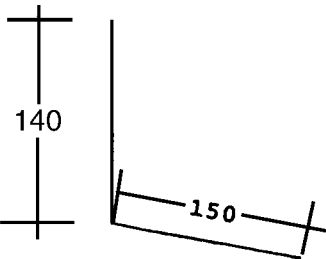
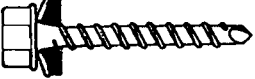
<p>A09 A10</p>  <p>BARGE PLATE (A) Length 2m/1.22m</p>	<p>A39 A40</p>  <p>SIDE FLASHING Length 2m/1.22m</p>	<p>A03</p>  <p>RIDGE TILE Length 2m</p>
<p>A09B A10B</p>  <p>BARGE PLATE (B) Length 2m/1.22m</p>	<p>A19 A20</p>  <p>MONO RIDGE Length 2m/1.22m</p>	<p>A04</p>  <p>END CAP Length n/a</p>
<p>A13 A14</p>  <p>RIDGE PLATE Length 2m/1.22m</p>	<p>A11 A12</p>  <p>EAVE PLATE Length 2m/1.22m</p>	<p>A42 A43 A44 Vent</p>  <p>STRIPSEAL (Ridge/eaves) Length 1.05m</p>
<p>A15 A16</p>  <p>VALLEY TRAY Length 2m/1.22m</p>	<p>A17 A18</p>  <p>TOP FLASHING Length 2m/1.22m</p>	<p>A01 A02</p>  <p>FIXING SCREWS Length 35mm/22mm</p>

NORDMAN - TRIM FITTINGS

ROOFING ACCESSORIES

A comprehensive range of accessories are available for all roofing requirements. The range includes Hip and Ridge Ties and Hip and Ridge Cappings, Barges, Eaves, Plate, Valley Trays, Edge Flashing and Pipe Flashings.

These accessories are fitted using self - drilling and tapping galvanized painted screws SL2 - T - A14 - 6.3 x 22mm. fixed to the top of the tile profile. To seal, protect and ventilate the roof other accessories are available to use in conjunction with the above list. Those accessories include stripseal filler blocks, comb fillers, expanding foam fillers and touch up paints.

PIPE FLASHING

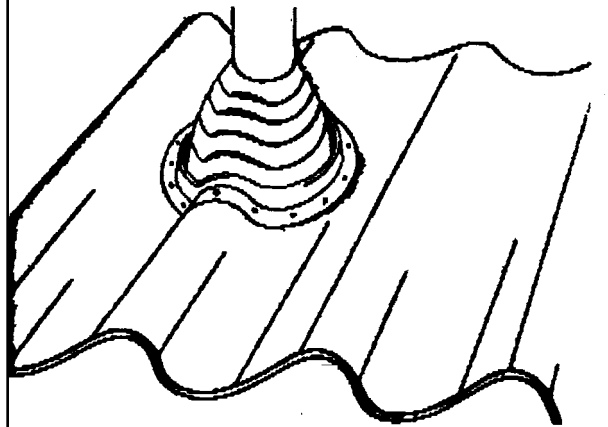

ACCESSORIES

Accessories

Barges, Ridge Tiles, Ridge Caps, Valley Trays, Eaves Plates etc., are supplied in 2 mts units and must be overlapped by 100mm.

Stripseal

Is supplied in 1050 mm units.

Fixing Screws

Screws are supplied in 2 lengths 22mm and 35mm available in boxes of 250. 7 screws per sq metre are required for fixing the Tilesheet.

Fixing Screws for accessories will amount to approx. 20% of the quantity required for fixing Tilesheets.
All accessories should be fixed at 350mm centres.

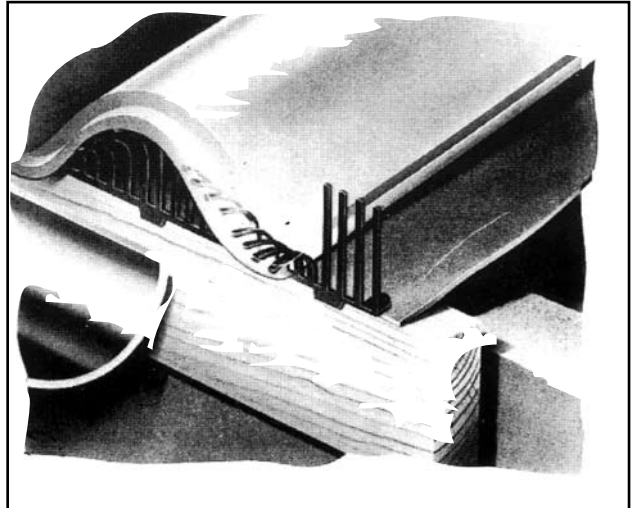

TOOLS AND EQUIPMENT

Footwear

Soft footwear with non-slip soles. (especially for high pitched roofs)

Cutting

NO ANGLE GRINDERS

For cutting a selection of the following tools will be required.

- .Nibbler
- .Power hacksaw with variable speed
- .A fine toothed hand saw
- .Tin-snips

Safety

Safety ropes, harness and ladders for high pitched roofs.

Fixing Tool

A drill with reverse action and torque setting.

Bending

Sheet metal vice grips for forming accessories.

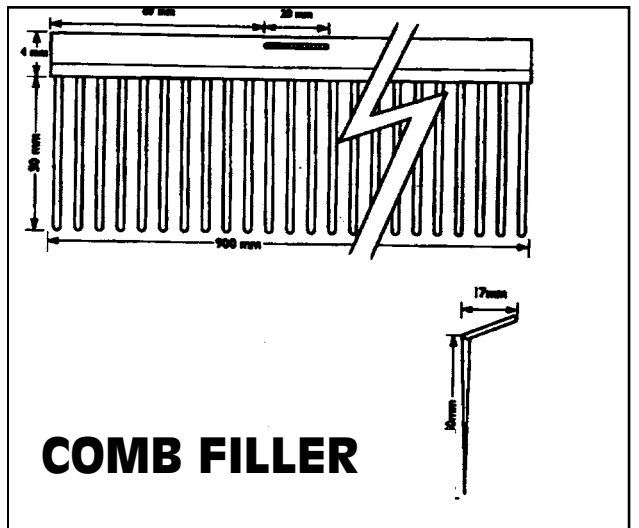

BATTENS

Nordman tilesheets are secured to the roof by fixing into timber battens. (See Fig. 1 batten sizes and spacing)

The first batten spacing is measured from the front face of the fascia board to meet the front face of the first batten. All other battens are spaced as per sketch.

NOTE: Fascia board is 15mm higher than battens

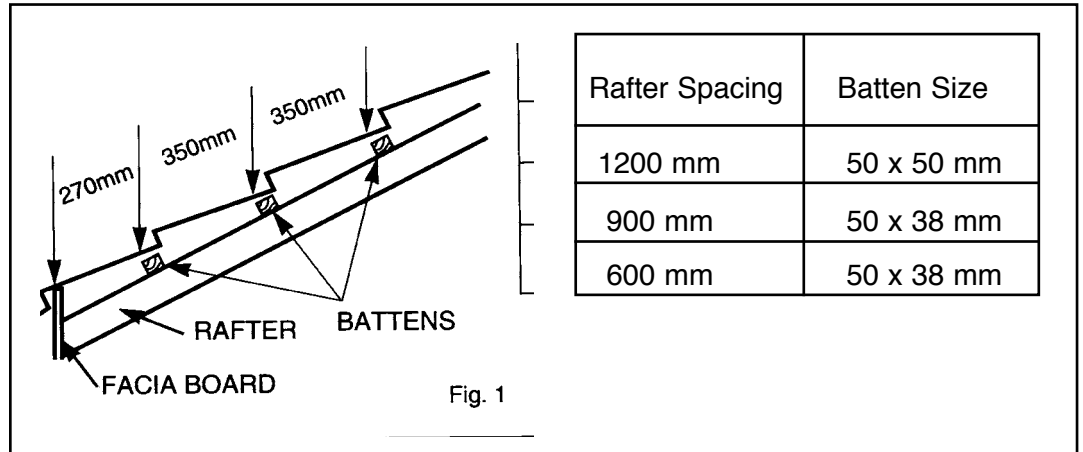

UNDERLAY/ROOFING FELT

The roofing felt must meet the requirements of BS 747 : 1977 SPECIFICATION FOR ROOFING FELTS or it must be covered by an Agreement Certificate and be fitted in accordance with that Certificate.

MEASURING THE ROOF

Nordman tilesheets are manufactured to individual roof requirements. Sheets are also available in standard lengths.

A. RAFTER LENGTH

Rafter length = length of sheet measured from ridge to eaves.

When a combination of sheet lengths is used, end to end, subtract 135 mm from each additional sheet length. i.e. A rafter length of 6435 mm requires 2 tilesheets of standard lengths 4335 and 2235.

B. ROOF LENGTH

To calculate the number of Tilesheets required, divide measurement 'B' by 1050 mm

C. HIPS AND VALLEYS

Must be calculated using graph paper

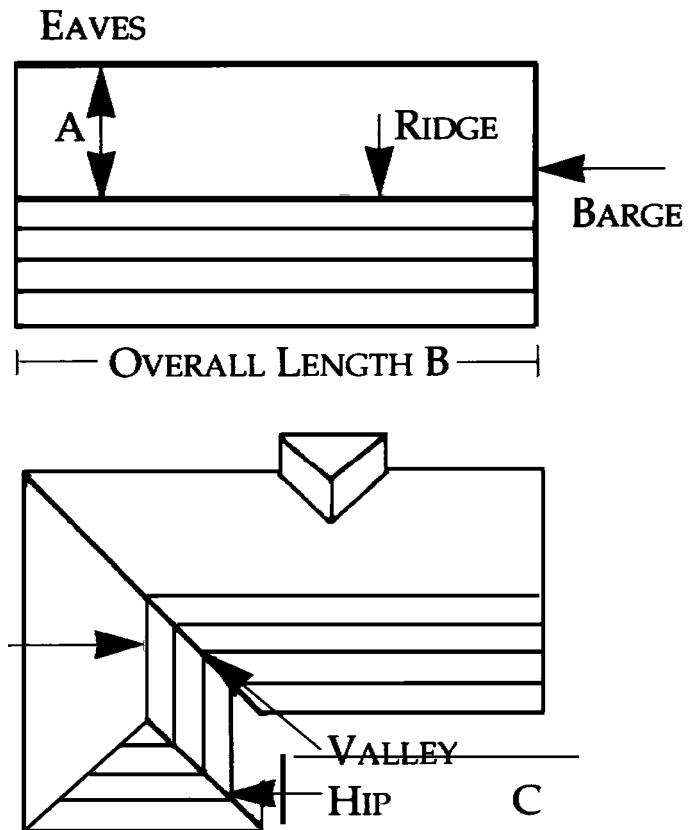

FIG 2

SUMMARY OF AGREEMENT CERTIFICATION NO: 05/4274

Nordman Tilesheets are certified for the use of roof pitches from 4° to vertical.

Nordman Tilesheets meet the requirements as defined in this Specification.

BUILDING REGULATIONS 1997:

All details of Nordman Tilesheets and accessories including manufacturing quality control checks are included.

TECHNICAL SPECIFICATION & CONTROL DATA:

Approved as per Nordman's Fitting Instructions.

Before certification the Agreement Board conducted tests including Behaviour in fire, strength & stability, weather tightness, effect of salt spray, safety, maintenance & durability.

FITTING THE TILESHEET

Tilesheets can be fitted starting from the right or left hand side, when starting at right hand side the sidelap will fit correctly in position. When fitting from left hand side the right hand side of the sheet must be lifted to allow underlapping ridge to fit underneath (see Fig 3A). Correct positioning of sheets is at the right angle to eave. The gables should not be used for positioning of sheets. When tilesheets are being fitted all precautions should be taken to avoid damage. Soft shoes should be worn and correct walking position used. (In the valley of the profile).

SIDE OVERLAPS

The Nordman tilesheets has an anti-capillary channel and it is not necessary to use any sealant on overlaps. The screws on side overlaps should be off centre of the tile valley (see Fig 3C).

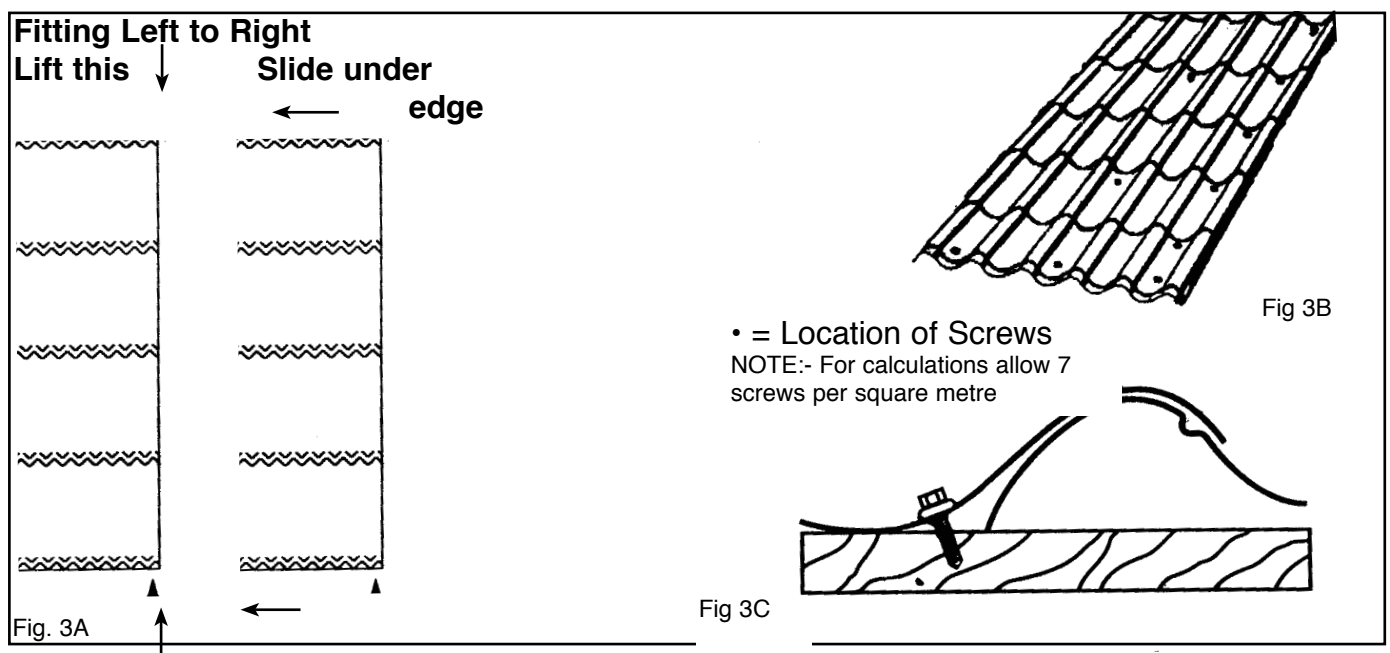

NORDMAN LAPPING DETAILS

Fitting Sequence when fitting Right to Left

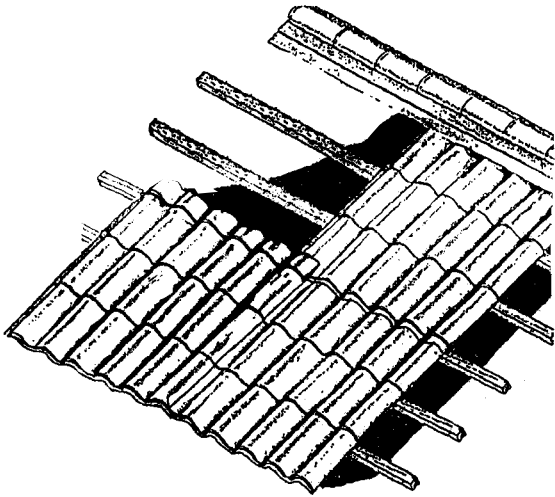

Fig 4A

Fitting Sequence when fitting Left to Right

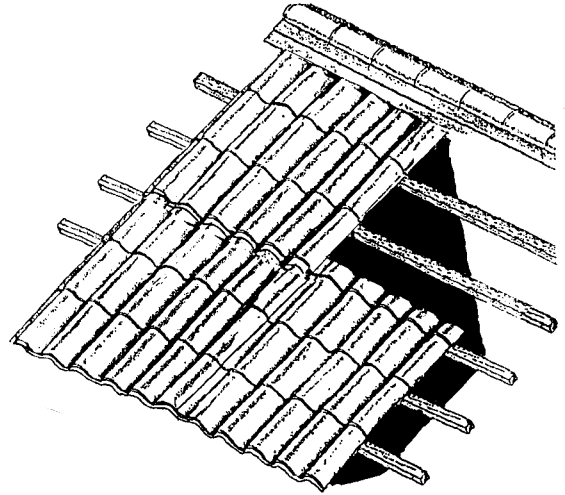

Fig 4B

Fig 5A

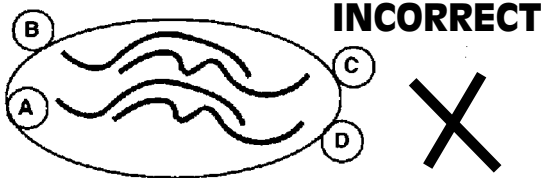
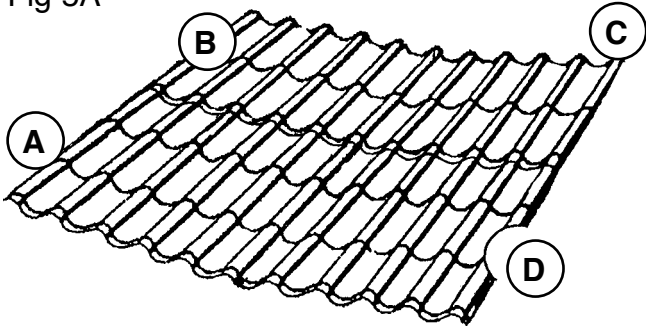
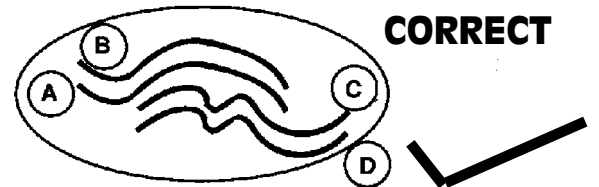
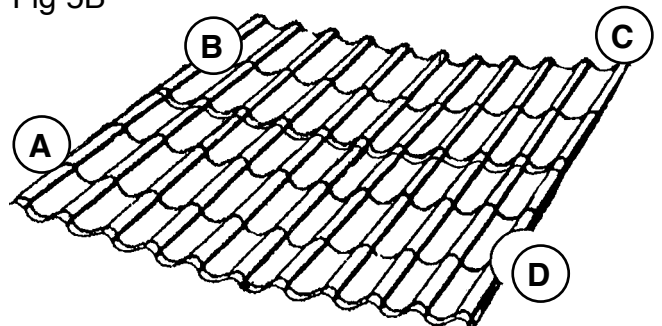
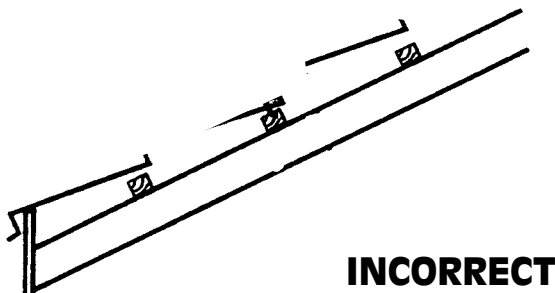

Fig 5B



END OVERLAPS
Do Not Fix Through
Both Top & Bottom
Sheet

Fig 6A



A. 20mm screw fixing through

END OVERLAPS

Fig 6B

- A. 22mm screw fixing through both roof sheet on ridge of the profile
- B. 35mm screw fixing into timber batten through bottom sheet only.

